

XA-4

Video Pattern Generator

Quick Guide

Operation Manual



XA-4

TABLE OF CONTENTS

1. Features and Specifications	3
Features	3
Specifications	3
2. Overview of the Remote Control	4
3. Installation and Connections	5
Front Panel	5
Rear Panel	6
4. Pattern table	6
5. Using the OSD main menu	9
5.1 Pattern	9
5.2 Audio source	9
5.3 HDCP setup	10
5.4 EDID analysis	10
5.5 Resolution	11
5.6 Signal type	11
5.7 Information	11

1. Features and Specification

Features

- Supports HDCP signal verification pattern.
- OSD menu operation
- Remote control

Specifications

- HDMI v1.2, HDCP1.1 and DVI1.0 compliant
- HDMI frequency bandwidth: 1.65Gbps (single link).
- Output Resolution:
PC Mode: VGA60 / SVGA60 / XGA60 / SXGA60 / UXGA60 / WUXGA60
HD Mode: 576p50 / 480p60 / 720p50 / 720p60 / 1080i50 / 1080i60 / 1080p50 / 1080p60
- Output Signal: DVI / HDMI / Auto Detect
- Patterns: 8 Groups with 36 patterns
- Audio Source:
1. Internal 1 kHz Sinewave 48kHz sampling rate
2. External optical input.
- HDMI Audio output:
1. From internal 1KHz Sinwave and converted to 8 channels LPCM, 48 KHz Sampling rate.
2. From external optical input.
- EDID support: VESA EDID v1.3 and EIA/CEA 861 Version 3.
- Input: optical x1
- Output: HDMI female port (type A connector) x1
- Power Supply: 5VDC/2A power supply (AC 90~240V).
- Weight (g): 334
- Dimensions (mm) (W x D x H): 125(W) x 125(D) x 30(H)

2. Overview of the Remote Control

① OSD menu operation

② PATTERN menu shows up.

③ Select a group of patterns.

④ Do EDID analysis.

⑤ Show system's information

⑥ Output Resolution Hot keys:

Press the Hot Keys for output resolution:
VGA60 / UXGA60 / WUXGA60 / 576p50
/ 480p60 / 720p60 / 1080i60 / 1080p60

⑦ HDCP turns on or off.

⑧ Select audio source - internal 1kHz sine wave or external optical

⑨ Select output signal type - DVI , HDMI or Auto-Detect

⑩ Reset system.

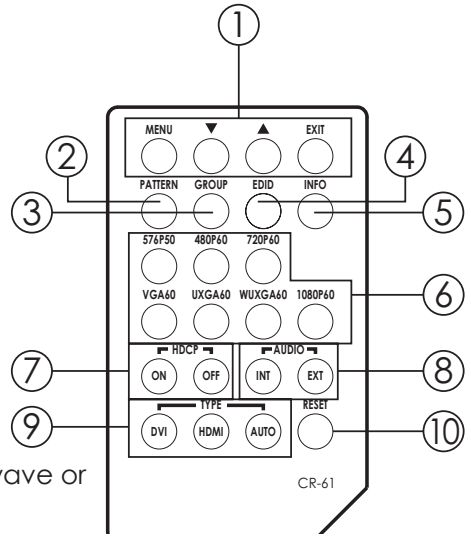

3. Installation and Connections Front Panel

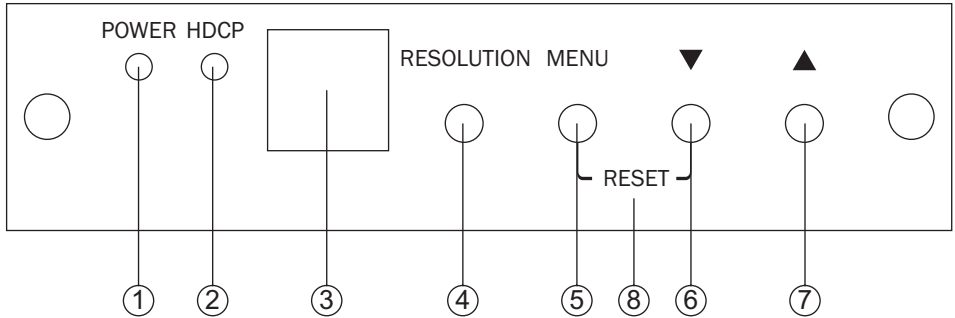

- ① Power ON/OFF indicator.
- ② HDCP ON/OFF indicator: Press [HDCP ON]/[HDCP OFF] to switch HDCP ON/OFF.
- ③ Remote control sensor.
- ④ Resolution: Switch resolution among VGA60→SVGA60→XGA60→SXGA60
→UXGA60→WUXGA60→576p50→480p60→720p50→720p60
→1080i50→1080i60→1080p50→1080p60
- ⑤ MENU (Enter): Press to view the OSD menu or press to enter the functions.
When OSD Menu shows up, the HDCP function will turn off by the system. After the OSD turn off, the HDCP function turn it on automatically.
- ⑥ ▼: Press to move the cursor down or switch to next pattern.
- ⑦ ▲: Press to move the cursor up or switch to previous pattern.
- ⑧ RESET: Press to return to factory setting.

Rear Panel

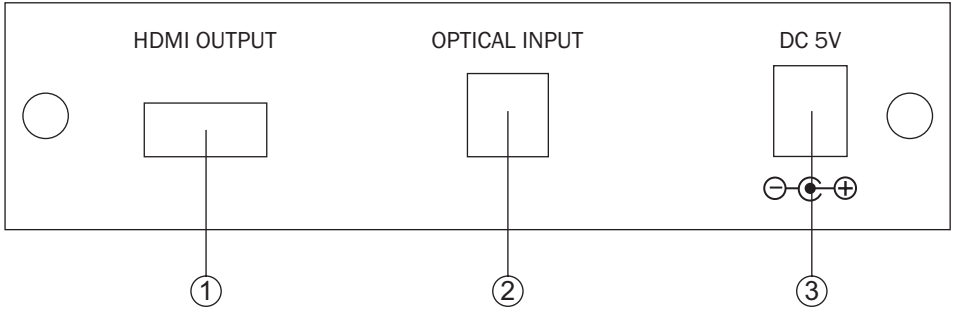

- ① HDMI OUTPUT: HDMI/DVI output.
- ② OPTICAL INPUT: Connected external S/PDIF audio source.
- ③ DC 5V/2A: Power input.

4. Pattern table

XA-4 has 8 groups with 36 patterns.

GROUP	PATTERN	COMMENT
Color Bar	① ② ③ ④	H/V color bars
Application		
<p>The color bar pattern in fact provides sufficient information for a good overall check on color performance. This includes the checks on burst keying, subcarrier regeneration, RGB amplifiers, the delay chrominance/luminance and saturation check.</p> <p>When the output resolution is 1080i 50/60, the pattern ③ and ④ are not supported.</p>		
Grey Scale		step8 / 16 / 32
Application		
<p>The Greyscale pattern is used to locate faulty linearity of the video amplifier or greyscale setting. Nonlinearities mainly result in a compression of the white level.</p>		

Purity		Purity Color White, Blue, Red, Magenta, Green, Cyan, Yellow, Black
--------	--	--

Application

The red and green patterns are most frequently used for checking color purity. In a correctly adjusted receiver, each electron beam will strike only one set of color dots or stripes on the screen. If the red pattern is selected only this color should be visible; the presence of any other color is an indication that color purity needs adjustment.

The green pattern provides a purity check for three in-line tubes. In addition the pattern serves as a reference to locate any geometrical distortions in these picture tubes. In the in-line tubes, the guns are in a horizontal position and the green gun is located in the center.

Blue as well as the complementary colors are often used to check the color performance.

The Patterns (mainly RED) are used to ensure that there is no interference between the sound and chroma carrier.

In addition to the primary and complementary colors 100% white can be selected as well as black pattern with color burst to check.

Furthermore purity patterns are used for measuring unwanted amplitude and phase modulation of the subcarrier, AM and PM noise as it occurs with VCRs.

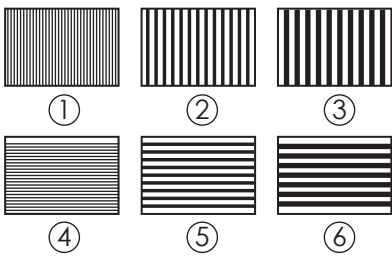

Black / White Line		H/V B/W line
--------------------	--	--------------

Application

The vertical pattern serves for a quick check of color monitor's horizontal bandwidth and phase behavior of a video transmission. Also, verify video amplifier and color temperature.

The horizontal pattern serves for a quick check of color monitor's vertical bandwidth and phase behavior of a video transmission. Also, verify video amplifier and color temperature.

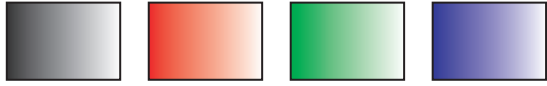
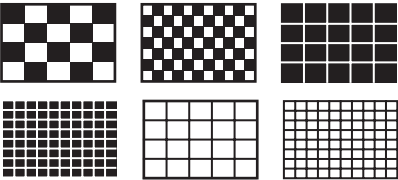
When the output resolution is 1080i 50/60, the pattern ④, ⑤ and ⑥ are not supported.

Gradual		Gradual Black/White, Red/White, Green/White, Blue/White
Application		
<p>Checks and adjustment of decoders, especially video de-emphasis and bell filters (cloche). In the receiver, after the antibell filter, the chrominance signal should have the same amplitude in the active video part.</p>		
Grid		Checker Board, Grid, Inverse Grid
Application		
<p>This pattern is mainly used for checking and aligning dynamic and corner convergence of TVs or monitors. When the output resolution is 1080i 50/60, the Grid patterns are not supported.</p>		
HDCP Pattern		HDCP test and link-integrity check
Application		
<p>To test DVI and HDMI receivers with HDCP. All DVI and HDMI options, including analyzer options, support HDCP production keys if the HDCP option is installed.</p>		
Others		H Pattern, Dot Pattern, Cross Center, Motion
Application		
<p>The H pattern is mainly used for checking aligning dynamic The Dot pattern is used for checking and adjusting the static convergence. The screen should contain pure white dots. The presence of colored dots points to faults in focusing and convergence. The Cross center is present in the corners of the screen to check and adjust the geometric distortion. The Cross center is ideal to center TV monitors and TV screens and alignment of picture height/picture width. Furthermore, it is used to check the deflection linearity and the pincushion correction. The Motion pattern is to check the correct digital video processing, especially AD conversion of modern TV equipment. When motion pattern ON, the HDCP function will turn off by system, After the user switch to other patterns, the HDCP function turn it ON automatically.</p>		

5. Using the OSD main menu

Press [MENU] to display main menu.

5.1 Pattern

Press [▲/▼] to move the cursor and then press [Menu] to enter the pattern mode. There are 8 different pattern groups; you can move the cursor and press [Menu] to enter each pattern group. Press [↑/↓] to select pervious/next pattern.

MANI MENU

PATTERN
AUDIO SOURCE
HDCP SETUP
EDID ANALYSIS
RESOLUTION
SIGNAL TYPE
INFORMATION
EXIT



PATTERN

COLOR BAR
GRAY SCALE
PURITY
BLACKWHITE LINE
GRADUAL
GRID
HDCP PATTERN
OTHERS
EXIT

Press [Exit/Menu] to return to pervious page. Or press [Exit/Menu] twice to return to the Main menu.

5.2 Audio source

Press [▲/▼] to move the cursor and then press [Menu] to enter the audio source. After the audio source been selected press [Menu] to confirm the selection.

MANI MENU

PATTERN
AUDIO SOURCE
HDCP SETUP
EDID ANALYSIS
RESOLUTION
SIGNAL TYPE
INFORMATION
EXIT



AUDIO SOURCE

INTERNAL
EXTERNAL
OFF
EXIT

Press [Exit/Menu] to return to the Main menu.

5.3 HDCP setup

Press [▲/▼] to move the cursor and then press [Menu] to enter the HDCP setup. After the HDCP setup been selected press [Menu] to confirm the selection.

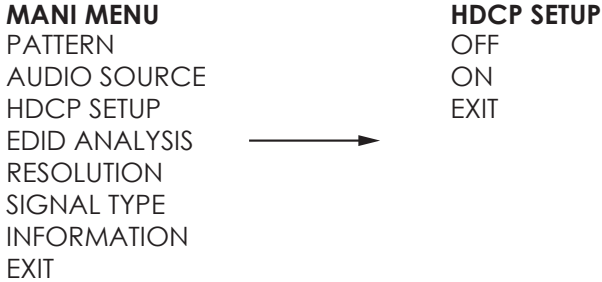

Press [Exit/Menu] to return to the Main menu.

5.4 EDID analysis

Press [▲/▼] to move the cursor and then press [Menu] to enter the EDID analysis. After enter EDID analysis sub-menu, the user can move the cursor and then press [Menu] to check the EDID information.

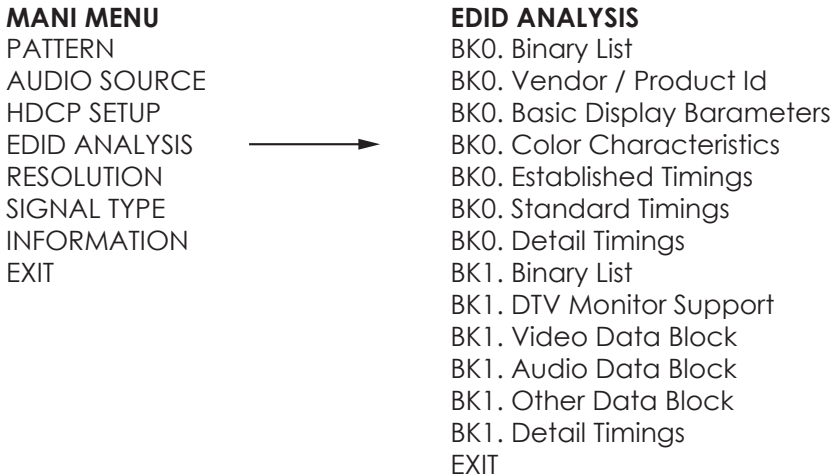

Press [Exit/Menu] to return to pervious page. Or press [Exit/Menu] twice to return to the Main menu.

5.5 Resolution

Press [▲/▼] to move the cursor and then press [Menu] to enter the resolution setup. After the resolution setup been selected press [Menu] to confirm the selection.

MANI MENU

PATTERN
AUDIO SOURCE
HDCP SETUP
EDID ANALYSIS
RESOLUTION
SIGNAL TYPE
INFORMATION
EXIT



RESOLUTION

PC Mode: VGA60 / SVGA60 / XGA60
SXGA60 / UXGA60 / WUXGA60
HD MODE: 576p50 / 480p60 / 720p50
720p60 / 1080i50 / 1080i60
1080p50 / 1080p60
EXIT

Press [Exit/Menu] to return to the Main menu.

5.6 Signal type

Press [▲/▼] to move the cursor and then press [Menu] to enter the signal type setup. After the signal type been selected press [Menu] to confirm the selection.

MANI MENU

PATTERN
AUDIO SOURCE
HDCP SETUP
EDID ANALYSIS
RESOLUTION
SIGNAL TYPE
INFORMATION
EXIT



SIGNAL TYPE

DVI
HDMI
AUTO DETECT
EXIT

Press [Exit/Menu] to return to the Main menu.

5.7 Information

Press [▲/▼] to move the cursor and then press [Menu] to show system information. The system default status as below:

MANI MENU

PATTERN
AUDKO SOURCE
HDCP SETUP
EDID ANALYSIS
RESOLUTION
SIGNAL TYPE
INFORMATION
EXIT



INFORMATION

RESOLUTION. 720P60
RATTERN. Color bar
AUDIO. internal
HDCP. OFF
SIGNAL TYPE. AUTO DETECT
DVI (depends on EDID of display device.)
EXIT

Press [Exit/Menu] to return to the Main menu.

Note: After the user change the system status, the information status will changed.

